

Technical information

Dimensions

Imperial

Metric

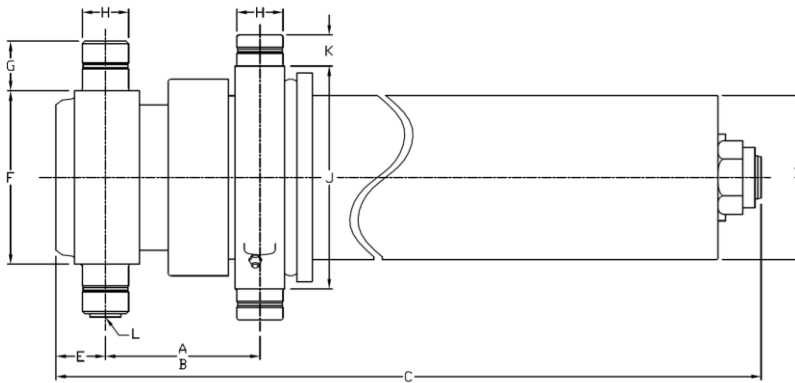

A (stroke)	171,94 in	4 367 mm
B (closed)	7,63 in	194 mm
C	57,69 in	1 465 mm
D	7,50 in	191 mm
E	2,00 in	51 mm
F	8,00 in	203 mm
G	2,00 in	51 mm
H	2,25 in	57 mm
J	10,19 in	259 mm
K	1,50 in	38 mm
L	SAE-16	

Stage	Effective diameter		Effective area		Stroke	
1	5,795 in	147 mm	26,38 in ²	17 016 mm ²	42,88 in	1 089 mm
2	5,000 in	127 mm	19,64 in ²	12 668 mm ²	43,25 in	1 099 mm
3	4,250 in	108 mm	14,19 in ²	9 152 mm ²	43,44 in	1 103 mm
4	3,500 in	89 mm	9,62 in ²	6 207 mm ²	42,38 in	1 076 mm

Specifications	Imperial	Metric
Weight without hydraulic fluid	459 lb	209 kg
Hydraulic fluid volume	14,8 gal. (US)	56 l
Maximum working pressure	2 750 psi	190 bar
Maximum pump flow	40 gpm	151 lpm
Cylinder design limit capacity*	29,6 US tons	26 853 kg

Installation components	Model	Part no.
Block	B-2250	PB3005003-A
Frame	AC-4040	PF3000014
Hinge	P-200 PEL-T	PP3004010

Cylinder capacity

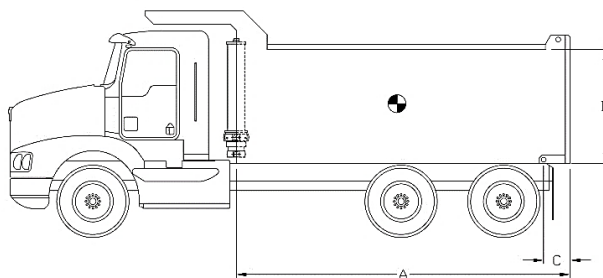

A = Body Length
B = Body height
C = Overhang

Note:	Body length	17,0 ft		18,0 ft		19,0 ft	
Cylinder capacities based on 90% of the maximum working pressure.	Overhang	0 in	6 in	6 in	12 in	6 in	12 in
	Dump angle	50,1°	51,7°	48,5°	50,1°	45,7°	47,1°
	Body height	Capacities for different box length configuration in US tons at 2000 psi (at 2750 psi)					
For reference only. See www.mailhotindustries.com	36 in	23,6 (32,5)	25,1 (34,5)	23,9 (32,9)	25,3 (34,9)	23,0 (31,7)	24,2 (33,3)
	48 in	24,9 (34,2)	26,6 (36,6)	25,1 (34,6)	26,8 (36,9)	24,0 (33,0)	25,4 (35,0)
	60 in	26,3 (36,2)	28,4 (39,0)	26,5 (36,5)	28,5 (39,2)	25,1 (34,6)	26,7 (36,8)

* See product manual

Subject to change without notice, all rights reserved.

REV 2C

Item	Part no.	Description
------	----------	-------------

1	ROV067027-A	BASE TUBE Ø6.7
2	RMG057195-A	SECTION Ø5.7
3	RMG050152-A	SECTION Ø5
4	RMG042151-A	SECTION Ø4.25
5	RNV035025-A	LAST SECTION Ø3.5
7	RK075150-A	COVER TUBE ASSEMBLY
8	RFG062008	END CAP Ø6.25
9	RFG062009	END CAP Ø6.25

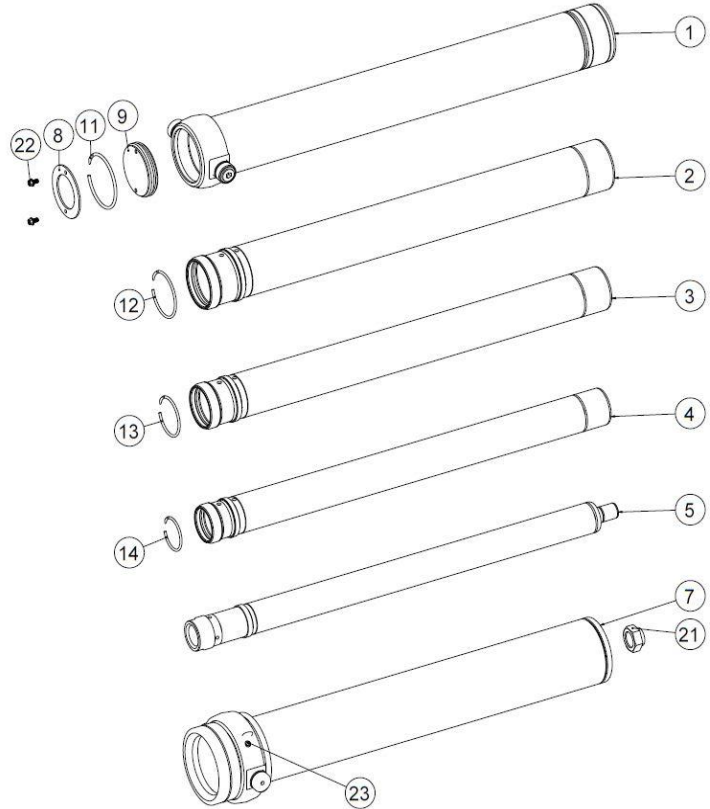

Snap ring kit Part no. : XB19G0574

Item	Description
11	SNAP RING Ø6-3/16
12	SNAP RING Ø5-1/4
13	SNAP RING Ø4-1/2
14	SNAP RING Ø3-3/4

Hardware kit Part no. : ZX02G0574

Item	Description
21	STOVER NUT Ø1-3/4-12 NF GRADE C
22	SERRATED FLANGE HHS GRADE 5 Ø3/8-16 UNC X 3/4 LG
23	GREASE FITTING STRAIGHT 1/8 NPT

Seal kit Part no. : UI47G0574

Item	Description
31	U-CUP Ø6.170 X Ø5.795 X 3/8
32	U-CUP Ø5-3/8 X Ø5 X 3/8
33	U-CUP Ø4-5/8 X Ø4-1/4 X 3/8
34	U-CUP Ø3-7/8 X 3-1/2 X 3/8
41	WIPER Ø5.795
42	WIPER Ø5
43	WIPER Ø4-1/4
44	WIPER Ø3-1/2
51	BACKUP RING Ø6-1/8 X Ø5-3/4
52	O-RING Ø6-1/8 X Ø5-3/4

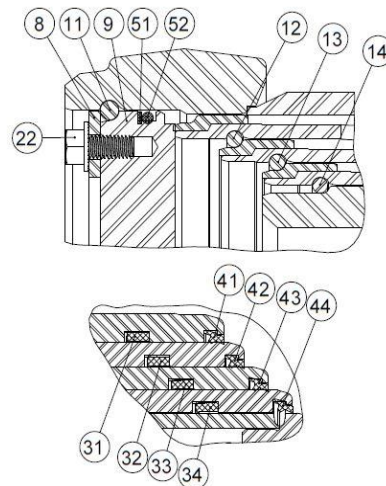

* See product manual

Subject to change without notice, all rights reserved.