

Technical information **Dimensions** **Imperial** **Metric**

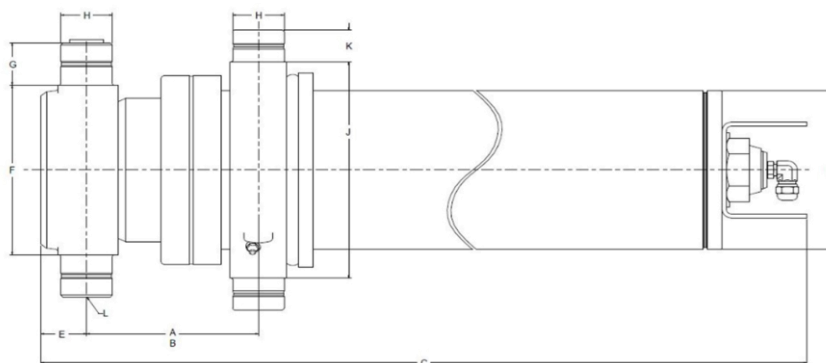

Dimensions	Imperial	Metric
A (stroke)	120,00 in	3 048 mm
B (closed)	6,25 in	159 mm
C	58,75 in	1 492 mm
D	6,63 in	168 mm
E	2,00 in	51 mm
F	7,00 in	178 mm
G	2,00 in	51 mm
H	1,87 in	48 mm
J	9,00 in	229 mm
K	1,25 in	32 mm
L	SAE-12	

Stage	Effective diameter	Effective area	Stroke
1	5,250 in / 133 mm	21,65 in ² / 13 966 mm ²	42,44 in / 1 078 mm
2	4,500 in / 114 mm	15,90 in ² / 10 261 mm ²	42,69 in / 1 084 mm
3	3,750 in / 95 mm	11,04 in ² / 7 126 mm ²	34,88 in / 886 mm

Specifications	Imperial	Metric
Weight without hydraulic fluid	333 lb	151 kg
Hydraulic fluid volume	8,1 gal. (US)	31 l
Maximum working pressure	2 500 psi	172 bar
Maximum pump flow ext. (retract.)	40 gpm (7 gpm)	151 lpm (26 lpm)
Cylinder design limit capacity*	29,6 US tons	26 853 kg

Installation components	Model	Part no.
Block	B-1875	PB3005002-A
Frame	AC-4030	PF3000013
Hinge	P-200 PEL-T	PP3004010

Cylinder capacity

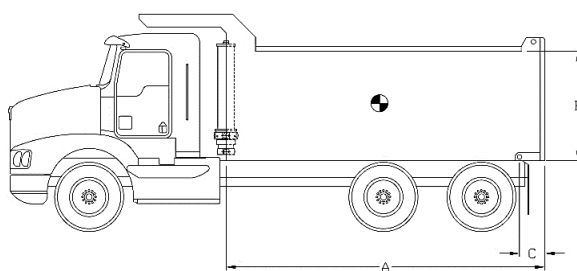

A = Body Length
B = Body height
C = Overhang

Note:	Body length	12,0 ft		13,0 ft		14,0 ft	
Cylinder capacities based on 90% of the maximum working pressure.	Overhang	0 in	6 in	6 in	12 in	12 in	18 in
	Dump angle	49,5°	51,8°	47,4°	49,5°	45,4°	47,4°
	Body height	Capacities for different box length configuration in US tons at 2000 psi (at 2500 psi)					
For reference only. See www.mailhotindustries.com	36 in	27,6 (34,5)	30,3 (37,9)	28,1 (35,2)	30,7 (38,4)	28,7 (35,8)	31,2 (39,0)
	48 in	29,7 (37,1)	33,0 (41,3)	30,1 (37,6)	33,3 (41,6)	30,5 (38,2)	33,7 (42,1)
	60 in	32,1 (40,1)	36,3 (45,3)	32,3 (40,4)	36,3 (45,4)	32,6 (40,8)	36,5 (45,6)

* See product manual

Subject to change without notice, all rights reserved.

Item	Part no.	Description
------	----------	-------------

1	ROVD059026-A	BASE TUBE Ø5.9
2	RMGD050172-A	SECTION Ø5
3	RMGD042171-A	SECTION Ø4-1/4
4	RNVD032078-A	LAST SECTION Ø3-1/4
7	RK066151-A	COVER TUBE ASSEMBLED
8	RFG053006	END CAP Ø5-3/8
9	RFG053007	END CAP Ø5-3/8

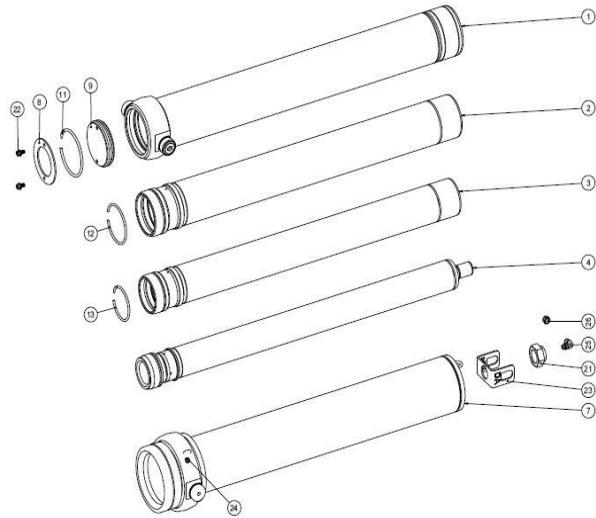

Snap ring kit Part no. : XB19G0503

Item	Description
------	-------------

11	SNAP RING Ø5-3/8
12	SNAP RING Ø4-1/2
13	SNAP RING Ø3-3/4

Hardware kit Part no. : ZX02G0503D

Item	Description
------	-------------

21	STOVER NUT 1-3/4-12 UN GRADE C
22	SERRATED FLANGE HSS GRADE 5 3/8-16 NC X 3/4 LG
23	PROTECTOR
24	GREASE FITTING STRAIGHT 1/8 NPT
25	ELBOW ADAPTER 90° SAE ORB TO 37° FLARE
26	CAP NUT SAE 37° FLARE Ø3/4-16
27	RELIEF VALVE PRESET 3200 PSI (3000-3500 PSI)

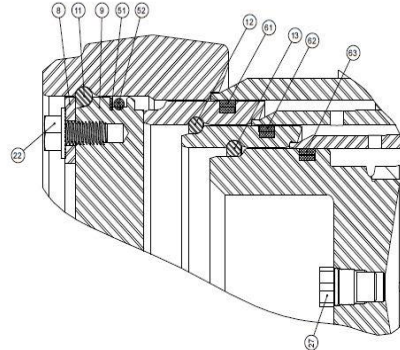

Seal kit Part no. : UI47G0503D

Item	Description
------	-------------

31	UCUP DZ Ø5-3/8 X Ø5 X 3/8
32	UCUP DZ Ø4-5/8 X Ø4-1/4 X 3/8
33	UCUP DZ Ø3-5/8 X Ø3-1/4 X 3/8
41	WIPER DT Ø5
42	WIPER DT Ø4-1/4
43	WIPER DT Ø3-1/4
51	BACKUP RING Ø5-3/8 X Ø5
52	O-RING Ø5-3/8 X Ø5
61	PISTON RING Ø5-1/4
62	PISTON RING Ø4-1/2
63	PISTON RING Ø3-3/4

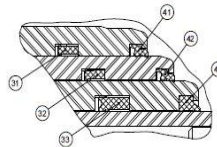

* See product manual

Subject to change without notice, all rights reserved.

REV 2A