

Technical information

Dimensions

Imperial

Metric

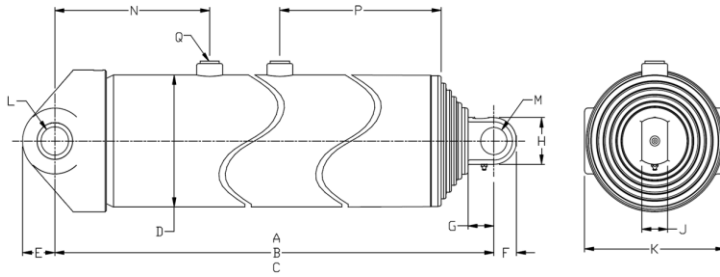

A (stroke)	166,94 in	4 240 mm
B (closed)	56,50 in	1 435 mm
C (opened)	223,44 in	5 675 mm
D	6,75 in	171 mm
E	2,00 in	51 mm
F	1,63 in	41 mm
G	2,00 in	51 mm
H	3,25 in	83 mm
J	2,00 in	51 mm
K	8,25 in	210 mm
L	2,13 in	54 mm
M	2,04 in	52 mm
N	12,00 in	305 mm
P	15,00 in	381 mm
Q	SAE-16	

Stage	Effective diameter		Effective area		Stroke	
1	5,795 in	147 mm	26,38 in ²	17 016 mm ²	41,25 in	1 048 mm
2	5,000 in	127 mm	19,64 in ²	12 668 mm ²	42,13 in	1 070 mm
3	4,250 in	108 mm	14,19 in ²	9 152 mm ²	42,50 in	1 080 mm
4	3,500 in	89 mm	9,62 in ²	6 207 mm ²	41,06 in	1 043 mm

Specifications	Imperial	Metric
Weight without hydraulic fluid	345 lb	157 kg
Hydraulic fluid volume	14,2 gal. (US)	54 l
Maximum working pressure	2 750 psi	190 bar
Maximum pump flow	40 gpm	151 lpm
Cylinder design limit capacity*	29,6 US tons	26 853 kg

Installation components	Model	Part no.
Block	-	-
Frame	-	-
Hinge	-	-

Cylinder capacity

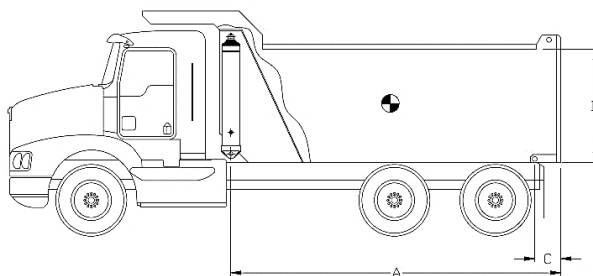

A = Body Length
B = Body height
C = Overhang

Note:	Body length	17,0 ft		18,0 ft		19,0 ft	
Cylinder capacities based on 90% of the maximum working pressure.	Overhang	0 in	6 in	6 in	12 in	12 in	18 in
	Dump angle	49,5°	51,2°	47,9°	49,5°	46,5°	47,9°
	Body height	Capacities for different box length configuration in US tons at 2000 psi (at 2750 psi)					
For reference only. See www.mailhotindustries.com	36 in	22,7 (31,2)	24,0 (33,0)	23,0 (31,6)	24,3 (33,4)	23,4 (32,1)	24,7 (33,9)
	48 in	23,9 (32,8)	25,4 (35,0)	24,2 (33,2)	25,7 (35,3)	24,5 (33,6)	26,0 (35,7)
	60 in	25,2 (34,7)	27,1 (37,2)	25,4 (35,0)	27,3 (37,5)	25,7 (35,3)	27,5 (37,8)

* See product manual

Subject to change without notice, all rights reserved.

REV 1C

Item	Part no.	Description
1	ROG067037-A	BASE TUBE Ø6,7
2	RMG057162-A	SECTION Ø5,7
3	RMG050099-A	SECTION Ø5
4	RMG042098-A	SECTION Ø4-1/4
5	RNG035049-A	LAST SECTION Ø3-1/2
7	SBG021082005	BUSHING
8	RFG062008	END CAP Ø6-1/4
9	RFG062009	END CAP Ø6-1/4

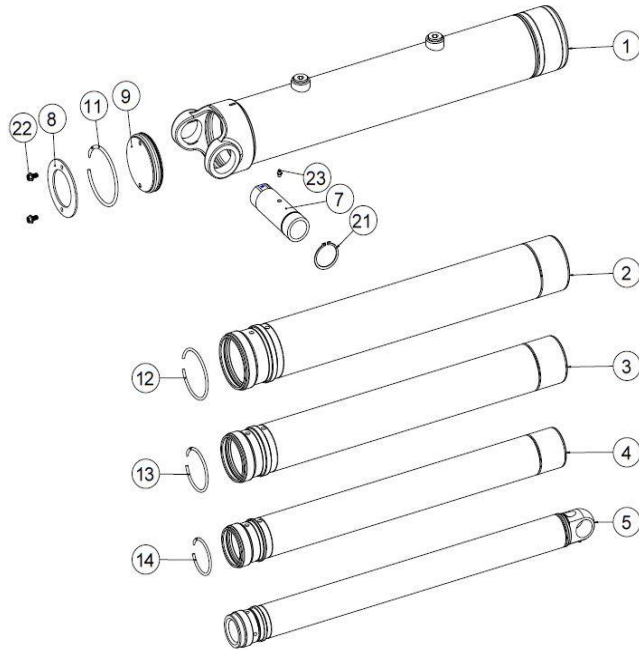

Snap ring kit Part no. : XB19G0574

Item	Description
11	SNAP RING Ø6-3/16
12	SNAP RING Ø5-1/4
13	SNAP RING Ø4-1/2
14	SNAP RING Ø3-3/4

Hardware kit Part no. : ZX03G0574

Item	Description
21	SNAP RING N5100-275
22	SERRATED FLANGE HHS GRADE 5 Ø3/8-16 NC X 3/4 LG
23	GREASE FITTING STRAIGHT 1/8 NPT

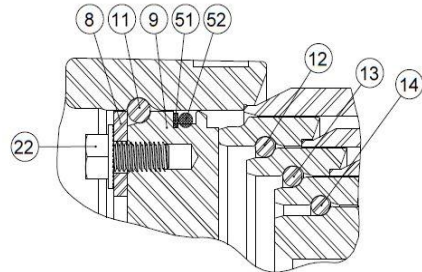

Seal kit Part no. : UI47G0574

Item	Description
31	U-CUP Ø6,170 X Ø5,795 X 3/8
32	U-CUP Ø5-3/8 X Ø5 X 3/8
33	U-CUP Ø4-5/8 X Ø4-1/4 X 3/8
34	U-CUP Ø3-7/8 X Ø3-1/2 X 3/8
41	WIPER Ø5,795
42	WIPER Ø5
43	WIPER Ø4-1/4
44	WIPER Ø3-1/2
51	BACKUP RING Ø6-1/8 X Ø5-3/4
52	O-RING Ø6-1/8 X Ø5-3/4

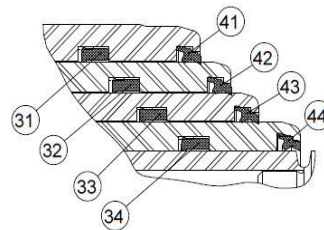

* See product manual

Subject to change without notice, all rights reserved.

REV 1C